



# magique totem

DESIGN  
STUDIO KLASS  
(M.MATURO E A.ROSCINI)

modello registrato  
registered model

portata su ogni ripiano: 10 kg  
load capacity on each shelf: 10 kg

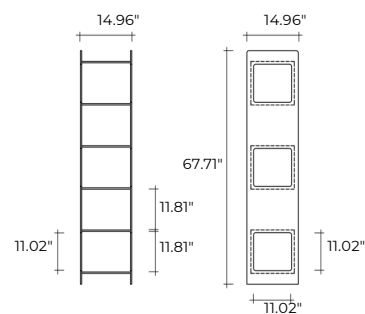

Espositore con cubi contenitori  
in vetro saldato da 0.39".  
Disponibile in diverse finiture.

Display cabinet with container cubes  
in 0.39" thick welded glass. Available  
in various finishes.

dimensioni L, P, H  
dimensions L, W, H

COD./CODE

L

P/W

H

peso netto peso lordo volume imballo  
net weight gross weight package volume  
(kg) (kg) (m<sup>3</sup>)

Espositore con struttura in vetro  
extralight, contenitori in vetro  
bianco opale (12 mm).  
Display cabinet with extralight glass  
frame, opal white glass containers  
(12 mm thick).

MQ/172XB

38

38

172

77,5

99,5

0,50

Espositore con struttura in vetro  
extralight, contenitori in vetro fumè.  
Display cabinet with extralight glass  
frame, smoked grey glass containers.

MQ/172XG

38

38

172

64

86

0,50

Espositore con struttura in vetro fumè,  
contenitori in vetro Nero95.  
Display cabinet with smoked grey glass  
frame, Black95 glass containers.

MQ/172GN

38

38

172

64

86

0,50

---

FINITURE  
FINISHES

---

Struttura  
Structure



vetro extralight  
extralight glass

Cubo contenitore  
Cubic inner compartment

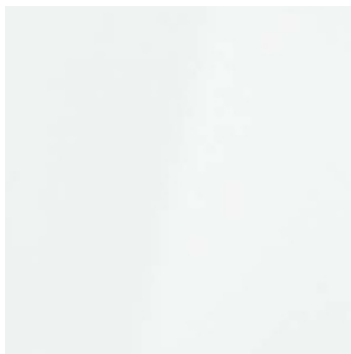

vetro bianco opale  
opal white glass

Struttura  
Structure

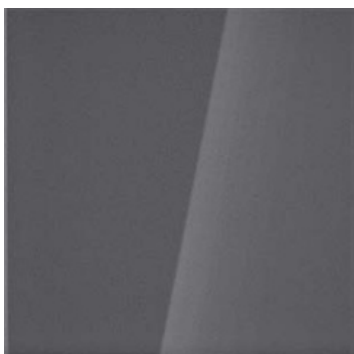

vetro fumè  
smoked glass

Cubo contenitore  
Cubic inner compartment



vetro Nero95  
Black95 glass

