



magique totem

DESIGN
STUDIO KLASS
(M.MATURO E A.ROSCINI)

modello registrato
registered model

portata su ogni ripiano: 10 kg
load capacity on each shelf: 10 kg

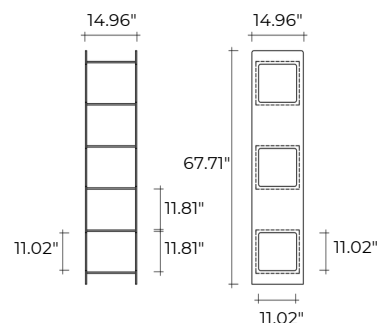

Espositore con cubi contenitori
in vetro saldato da 0.39".
Disponibile in diverse finiture.

*Display cabinet with container cubes
in 0.39" thick welded glass. Available
in various finishes.*

dimensioni L, P, H <i>dimensions L, W, H</i>	COD./CODE	L	P/W	H	peso netto <i>net weight</i> (kg)	peso lordo <i>gross weight</i> (kg)	volume imballo <i>package volume</i> (m ³)
Espositore con struttura in vetro extralight, contenitori in vetro bianco opale (0.47"). <i>Display cabinet with extralight glass frame, opal white glass containers (0.47" thick).</i>	MQ/172XB	14.96"	14.96"	67.71"	77,5	99,5	0,50
Espositore con struttura in vetro extralight, contenitori in vetro fumè. <i>Display cabinet with extralight glass frame, smoked grey glass containers.</i>	MQ/172XG	14.96"	14.96"	67.71"	64	86	0,50
Espositore con struttura in vetro fumè, contenitori in vetro Nero95. <i>Display cabinet with smoked grey glass frame, Black95 glass containers.</i>	MQ/172GN	14.96"	14.96"	67.71"	64	86	0,50

FINITURE
FINISHES

Struttura
Structure



vetro extralight
extralight glass

Cubo contenitore
Cubic inner compartment



vetro bianco opale
opal white glass

Struttura
Structure

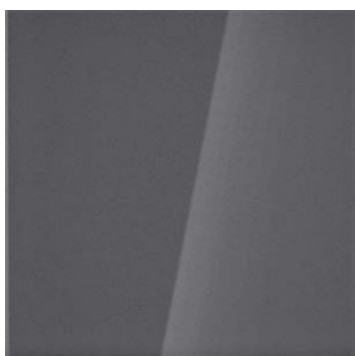

vetro fumè
smoked glass

Cubo contenitore
Cubic inner compartment



vetro Nero95
Black95 glass