

INSTALLATION GUIDE X4P

INFINII

UNIVERSAL SYSTEMS FOR FRAMELESS DOORS

GENERAL INFORMATION

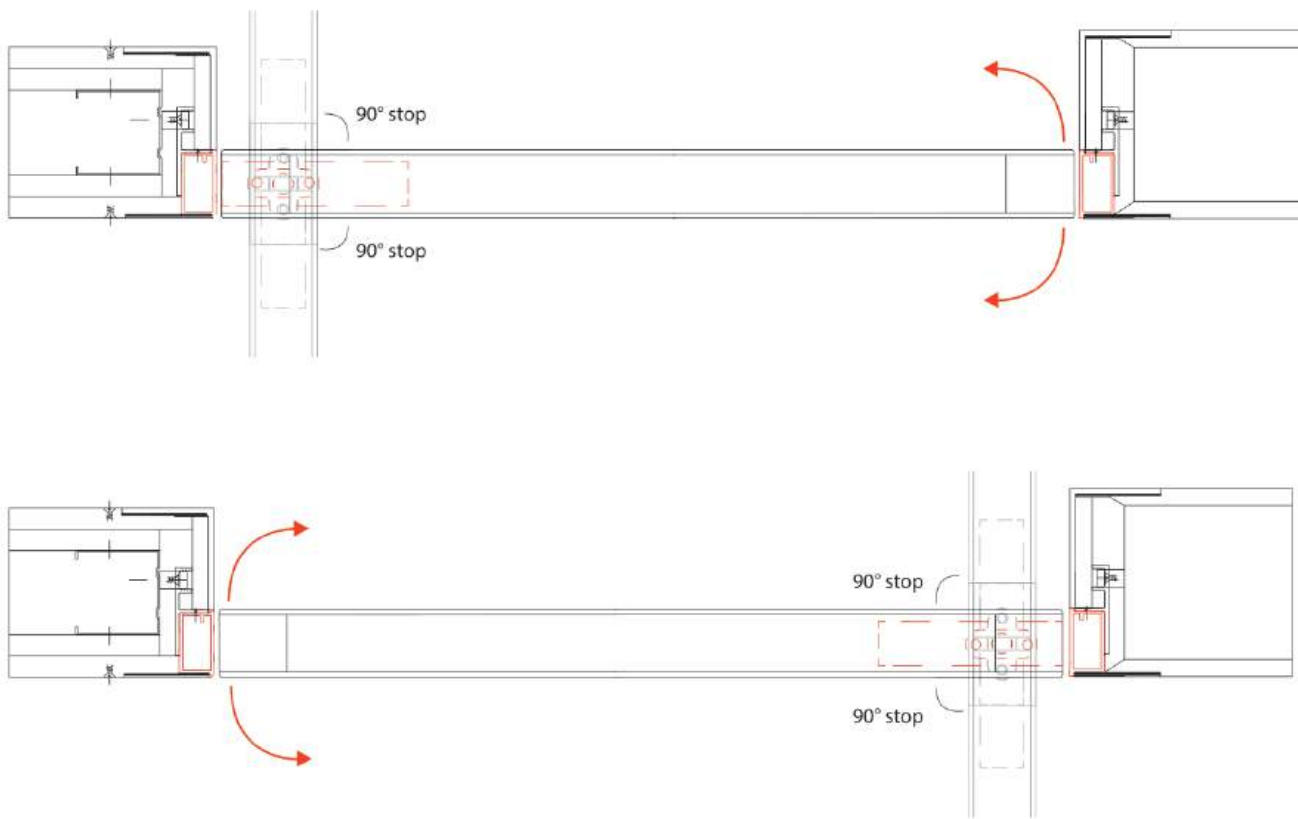

DEURFRAME | CADRE DE PORTE | DOOR FRAME | UNIVERSALZARGE

- 1 Staanders + bevestigingsprofielen + NZ slot
Montants + profilés de fixation + serrure NZ
Uprights + fixation profiles + NZ lock
Pfosten + Befestigungsprofile + NZ Schloss



- 2 Kopstuk + afstandshouders + pivot zelfsluitend 90° stop
Traverse + écarteurs + pivot intégré auto-fermant arrêt 90°
Upper rail + spacer bars + pivot self closing with 90° stop
Querleiste + Abstandhalter + Pendeltürmechanismus selbstschließend mit 90° stop



TYPES

BREEDTE DEURBLAD | LARGEUR DU PANNEAU | WIDTH DOOR LEAF | BREITE TÜRLATT

730 780

830 880

930

1030

HOOGTE DEURBLAD | HAUTEUR DU PANNEAU | HEIGHT DOOR LEAF | HÖHE TÜRLATT

2015 2040

2115

2315

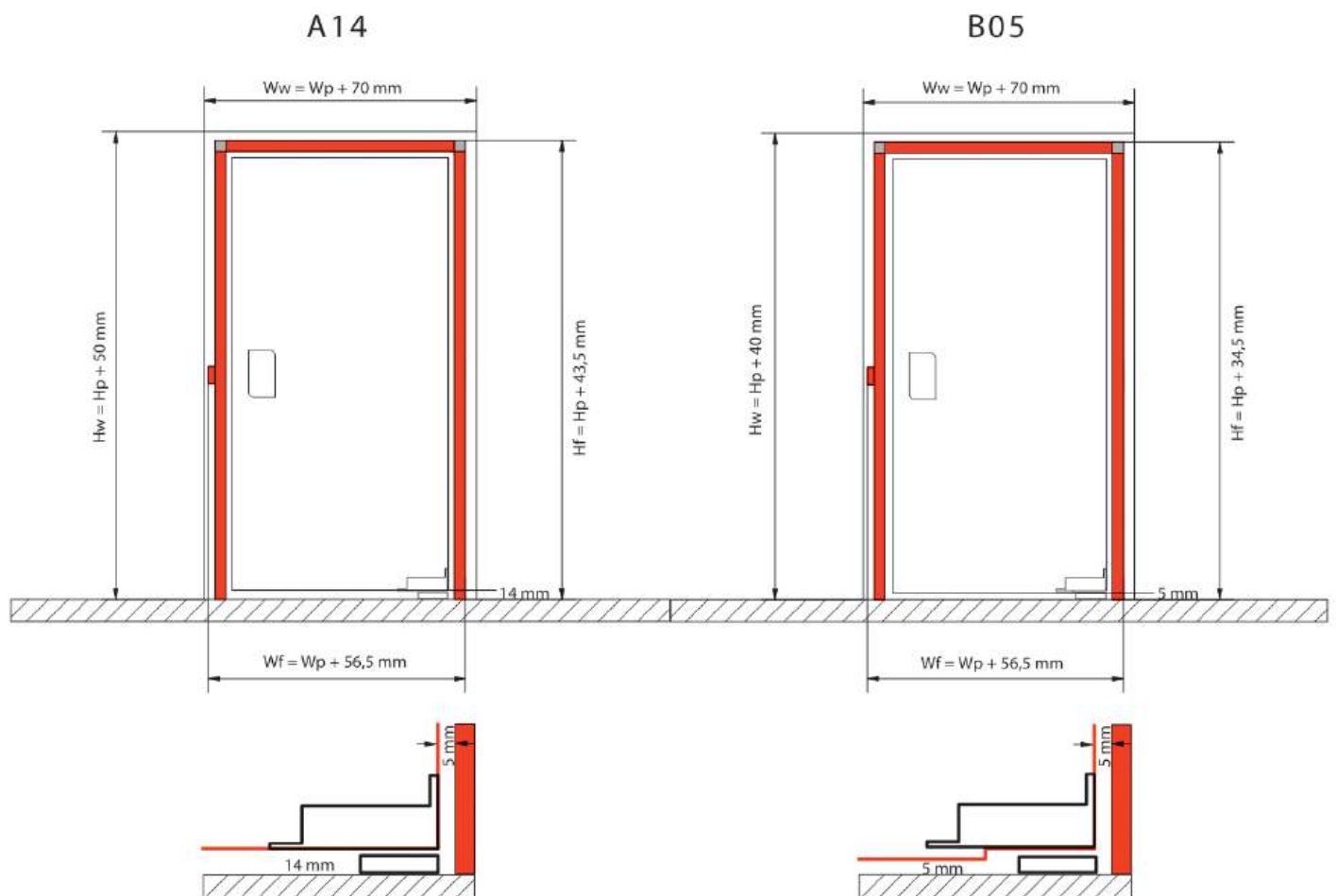

H_p = Hoogte deur
Hauteur de panneau
Height door panel
Höhe Türblatt

H_f = Hoogte frame
Hauteur huisserie
Height door frame
Rahmenhöhe

H_w = Hoogte wandopening
Hauteur d'ouverture de mur
Opening height wall
Höhe Wandöffnung

W_p = Breedte deur
Largeur de panneau
Width door panel
Breite Türblatt

W_f = Breedte frame
Largeur huisserie
Width door frame
Rahmenbreite

W_w = Breedte wandopening
Largeur d'ouverture de mur
Opening width wall
Breite Wandöffnung

INSTALLATION POSITIONS

1 X FRAME = 4 POSITIONS

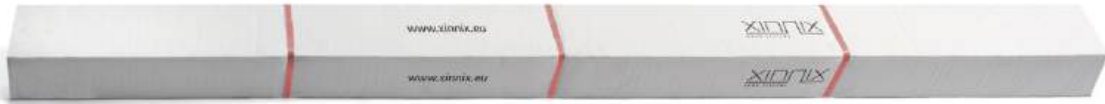

FLUSH INSTALLATION

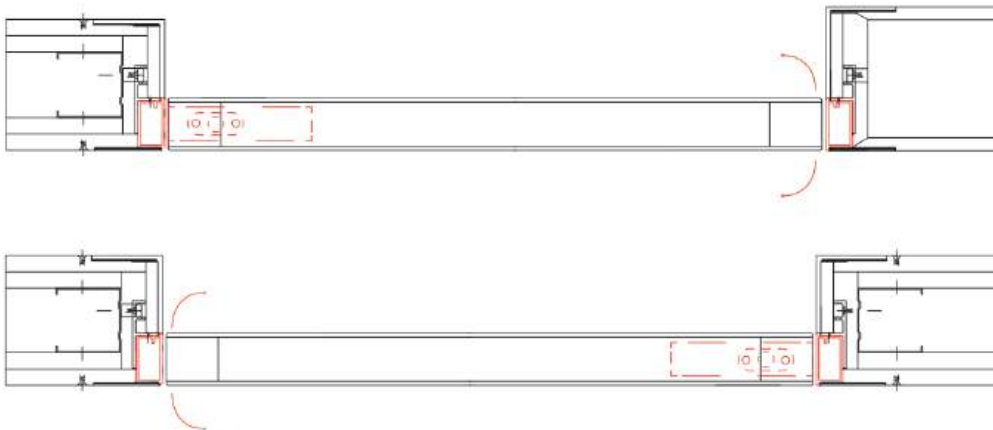

CENTRAL INSTALLATION

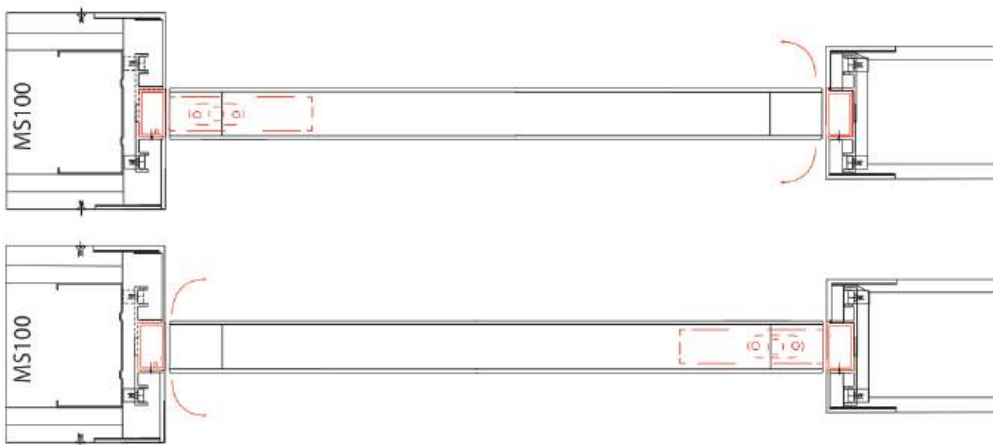

EXPLODED VIEW - FLUSH INSTALLATION

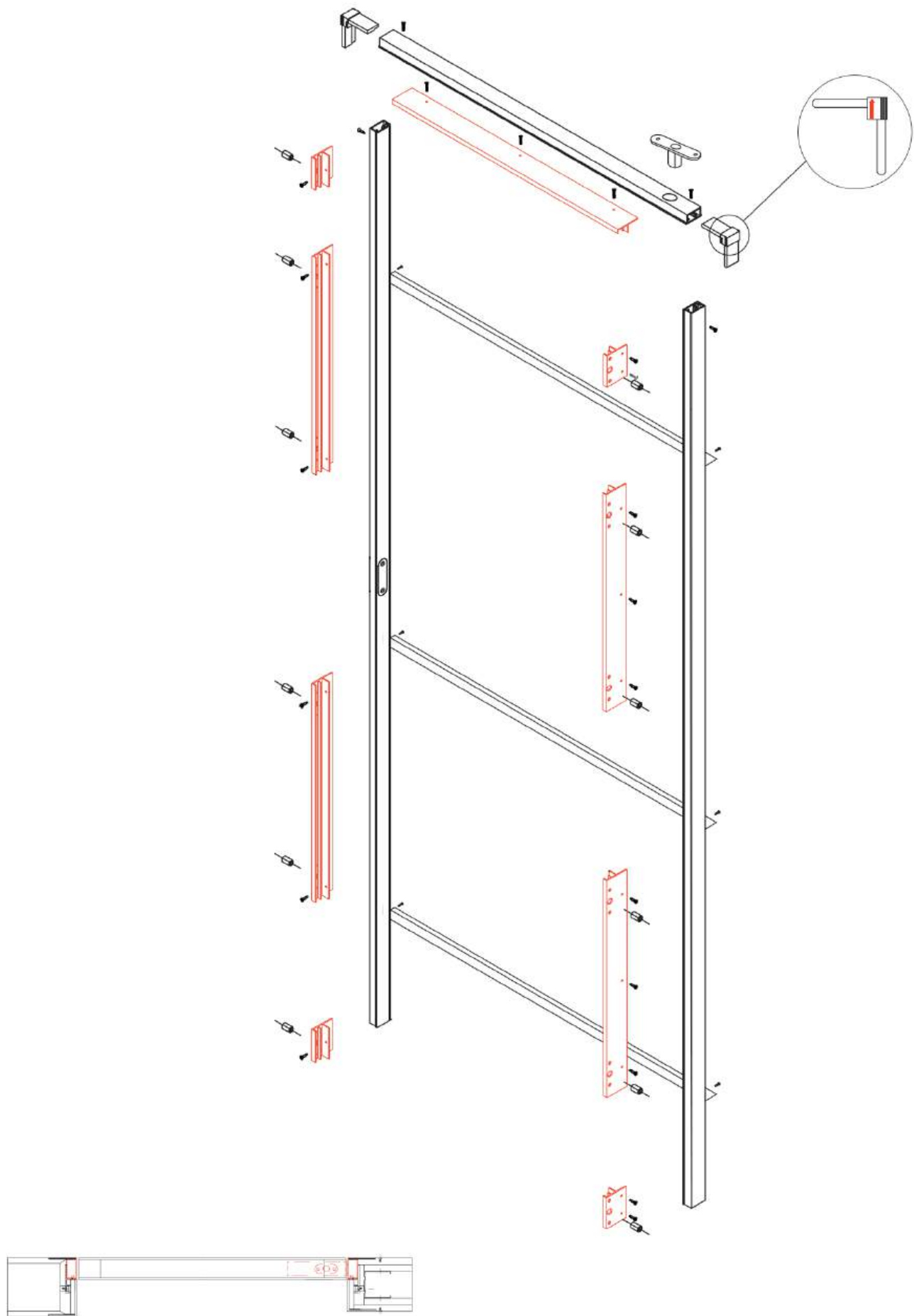

EXPLODED VIEW - CENTRAL INSTALLATION

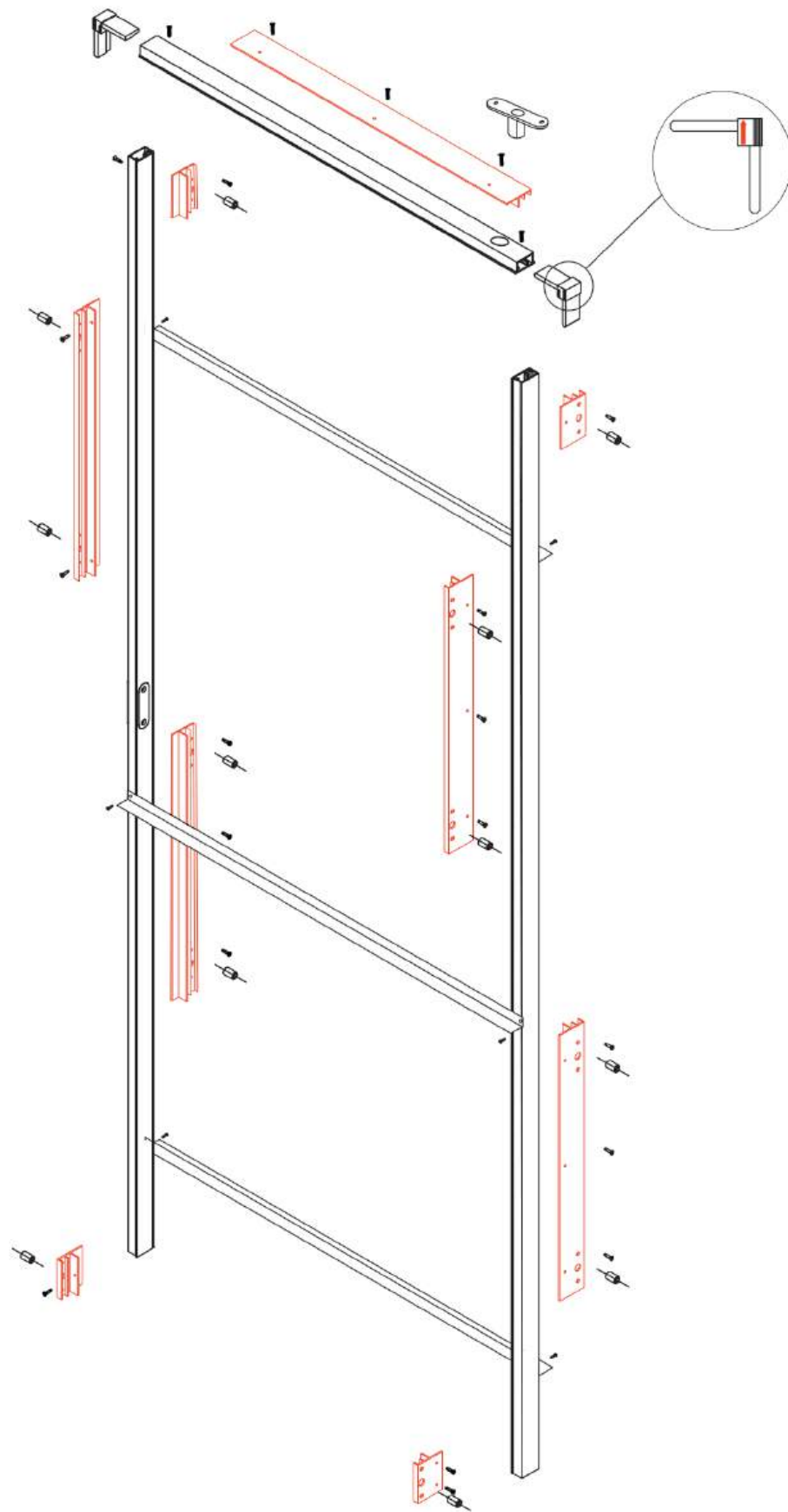

CUTTING DOWN THE FRAME

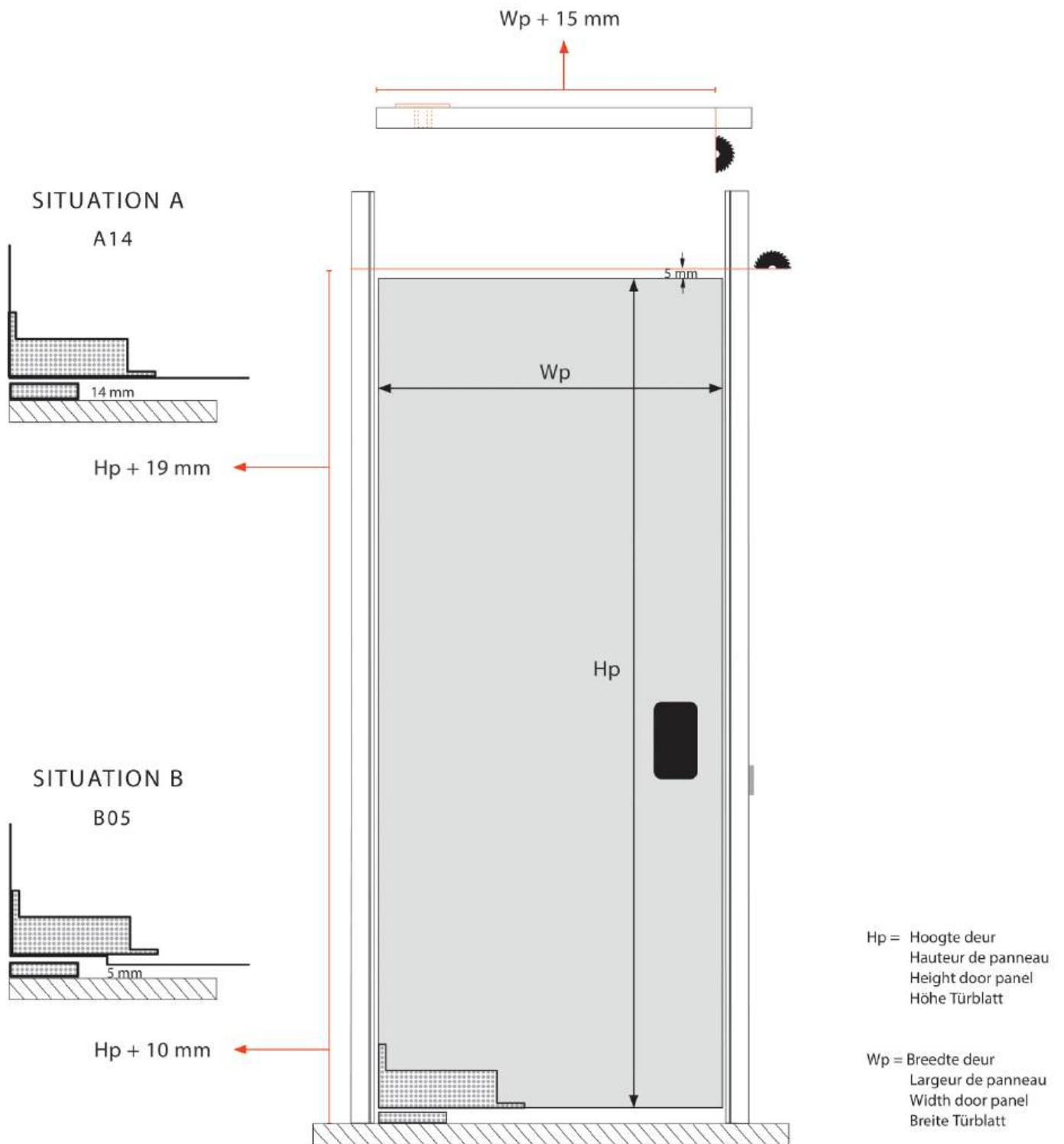

INSTALLATION STEPS

BOX PIVOT

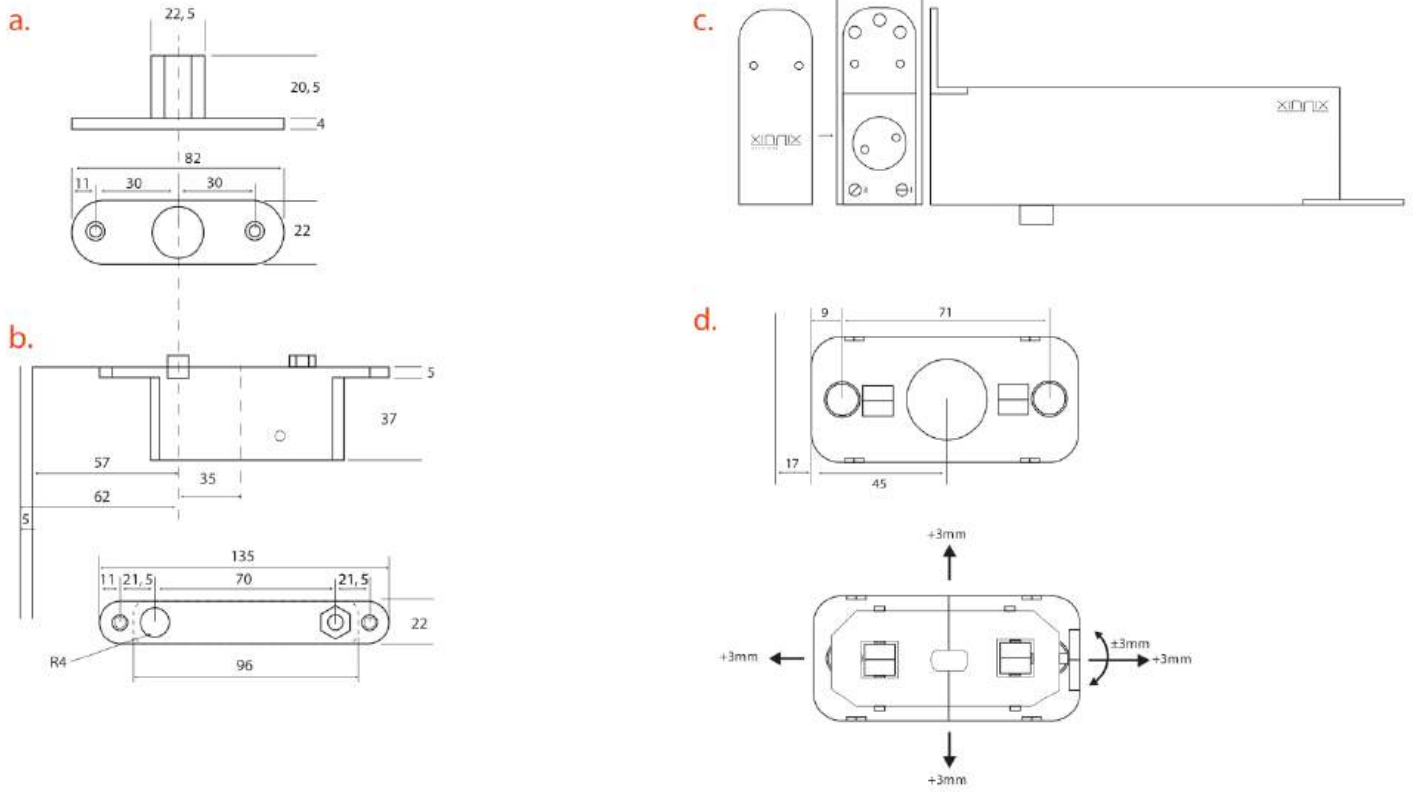

VENTILATION

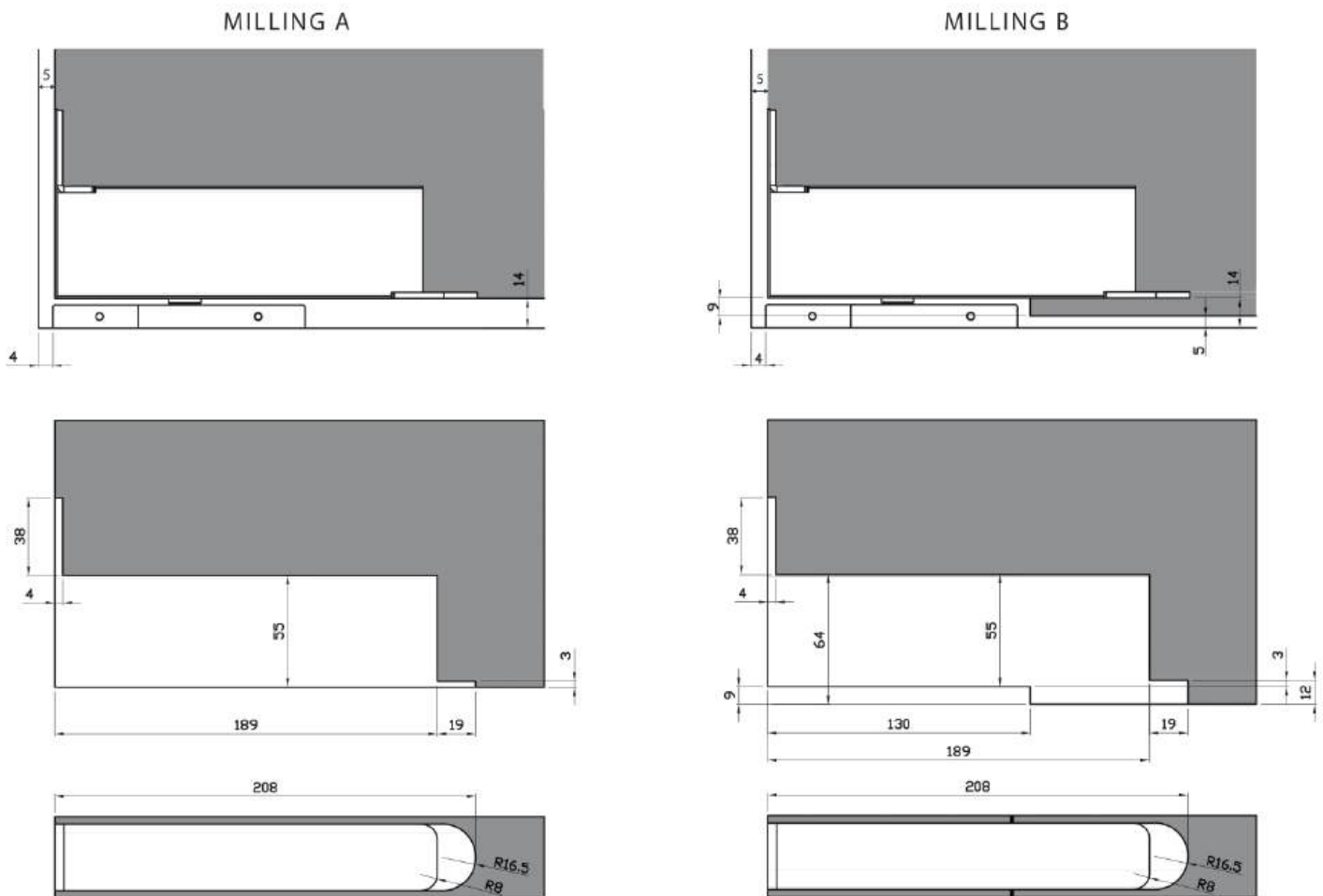

INSTALLATION STEPS

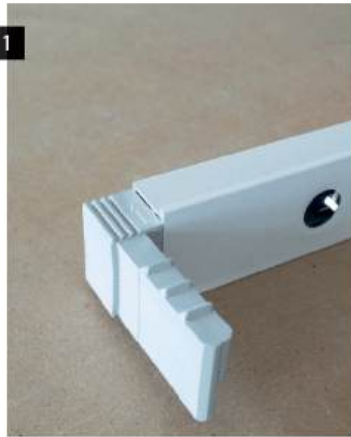

1

Monteer de verbindingshoeken in het kopstuk. De pijl moet naar boven wijzen. Schroef ze nog niet vast.

Installez les pièces de liaison dans la traverse. La flèche doit être dirigée vers le haut. Ne les fixez pas encore.

Install the connection corners in the upper rail. The arrow should point upwards. Do not screw them in yet.

Montieren Sie die Verbindungsecken im Querleiste. Der Pfeil muss nach oben weisen. Schrauben Sie diese noch nicht an.



2

Monteer (a) in het profiel zoals op de foto en schroef vast. Schroef de verbindingshoeken vast.

Fixez (a) dans le profil comme dans l'image et fixez les. Ensuite, fixez les pièces d'assemblage.

Install (a) in the profile as in the picture and attach. Then attach the connection parts.

Montieren Sie (a) im Profil wie auf dem Foto und festschrauben. Schrauben Sie die Verbindungsecken an.



3

Bevestig de staanders aan het kopstuk en schroef ze vast.

Fixez les montants à la traverse et vissez-les.

Attach the uprights to the upper rail and screw them into place.

Stecken Sie die Pfosten auf das Querleiste und schrauben Sie diese fest.



4

Bevestig de bevestigingsprofielen en de afstandshouders aan het systeem volgens de montage posities op pagina 6 of 7.

Fixez les profilés de fixation et les écarteurs au système selon les positions de montage sur la page 6 ou 7.

Attach the fixation profiles and the spacer bars to the system according to the installation positions on page 6 or 7.

Bringen Sie die Befestigungsprofile und die Abstandhalter gemäß den Montagepositionen auf Seite 6 oder 7 am System an.

INSTALLATION STEPS



5

Zet het systeem waterpas aan de hand van de stelschroeven.

Mettez le système à niveau à l'aide des vis de réglage.

Level the system using the levelling screws.

Nivellieren Sie das System mit den Nivellierschrauben.



6

Bevestig het systeem aan de muur en fixeer met PUR-schuim.

Attachez le système au mur et fixez-le avec de la mousse PUR.

Attach the system to the wall and fix with PUR foam.

Das System an der Wand befestigen und mit PUR-Schaum fixieren.



7

Monteer (b), (c) en het NZ slot in het deurblad.

Installez (b), (c) et la serrure NZ dans le panneau de porte.

Install (b), (c) and the NZ lock into the door leaf.

Montieren Sie (b), (c) und das NZ-Schloss in das Türblatt.



8

Bevestig (d) op de vloer.

Fixez (d) au sol.

Attach (d) to the floor.

Befestigen Sie (d) auf dem Boden.

INSTALLATION STEPS



9

Monteer de deur in het systeem. Haal pin (b) eruit met behulp van de steeksleutel.

Installez la porte dans le système. Libérez la goupille de (b) à l'aide de la clé.

Install the door into the system. Let the pin of (b) come out by using the wrench.

Bauen Sie die Tür in das System ein. Lösen Sie den Stift von (b) mit Hilfe des Schraubenschlüssels.

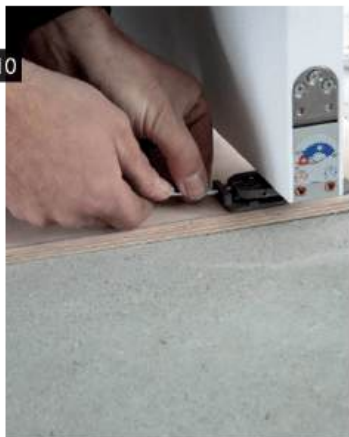

10

Regel de positie bij.

Ajustez la position.

Adjust the position.

Position einstellen.

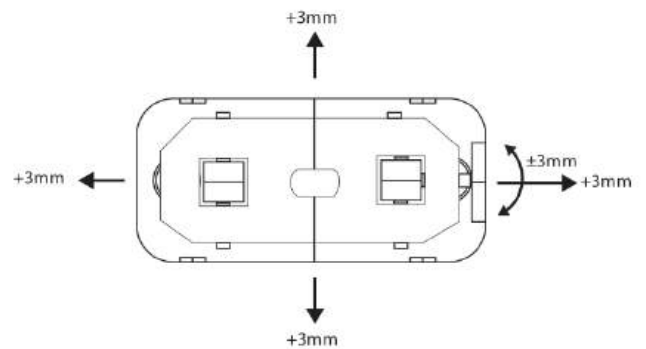

11

Regel de sluitsnelheid bij.

Réglez la vitesse de fermeture.

Adjust the closing speed.

Stellen Sie die Schließgeschwindigkeit ein.

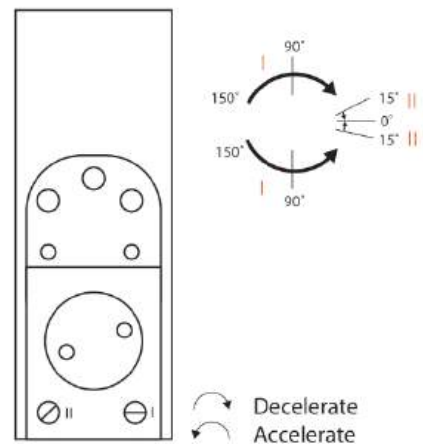

12

Bevestig de afdekplaat van (d) en (c).

Fixez la plaque de finition de (d) et (c).

Attach the cover plate of (d) and (c).

Bringen Sie die Abdeckplatte von (d) und (c) an.

XP50 © - UNIVERSAL INTEGRATED XINNIX PLINTH

XP50

- a** X3
- b** XP50-C002
- c** XP50 + XP50-Cover
- d** XP50-C001
- e** XP50-A045 (+45°/ -45°)

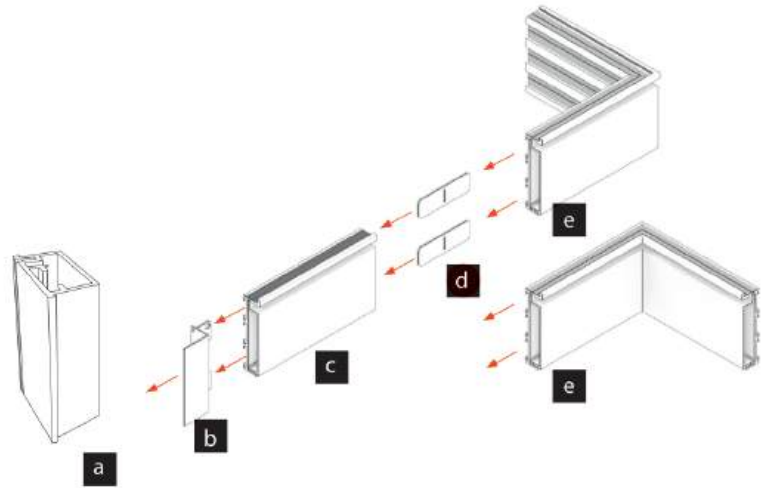

XP50-04

MINIMALISTIC PLINTH FOR FLUSH INSTALLATION

- All installation and adjustment pieces are available
- Glued invisible in the wall construction
- Dimensions: 50 x 4 mm

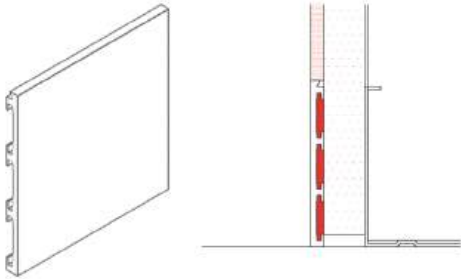

□	XP50.04-3000.W	Plinth 3000 mm - White primer
■	XP50.04-3000.BL	Plinth 3000 mm - Lacquered black

FINISHING PROFILE

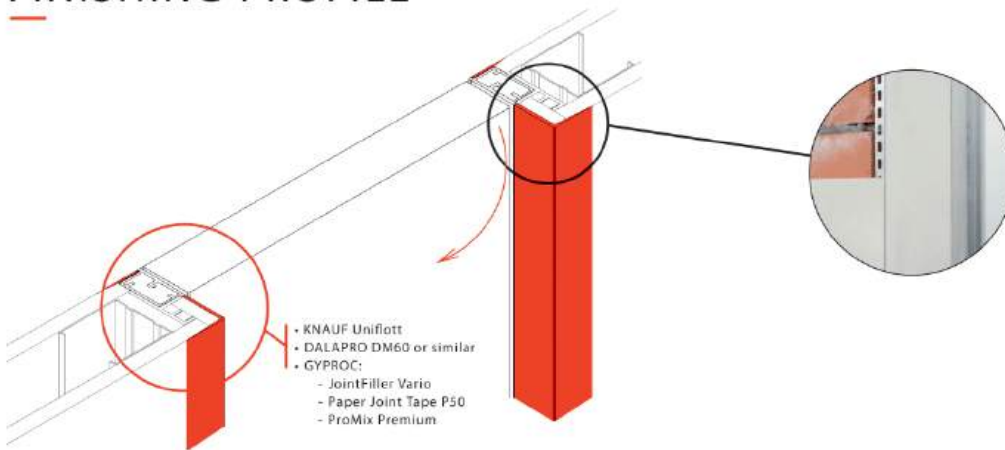

- KNAUF Uniflott
- DALAPRO DM60 or similar
- GYPROC:
 - JointFiller Vario
 - Paper Joint Tape P50
 - ProMix Premium



PACKAGINGS PER 5

ORDER CODE
XA-FIN2200/120
XA-FIN2200/260
XA-FIN2600/120
XA-FIN3000/120
XA-FIN3000/260

PACKAGINGS IN DOOR SETS

ORDER CODE
XA-FIN2088/140/KE1
XA-FIN2200/120/KE1
XA-FIN2200/120/KE2
XA-FIN2600/120/KE1
XA-FIN2600/120/KE2

HARDWARE



XA-NZ.W



XA-NZ.B



XA-NZ.G



XA-NHNS200

NZ



XA-938



XA-937



XA-998NH.CS



XA-NH003I



XA-NH004M
XA-NH006M



XA-D70BB.CS	🔑
XA-D73WC.CS	🔑
XA-D78PZ.CS	🔑



XA-I97.W



XA-I97.G



XA-I97.B

NOTES

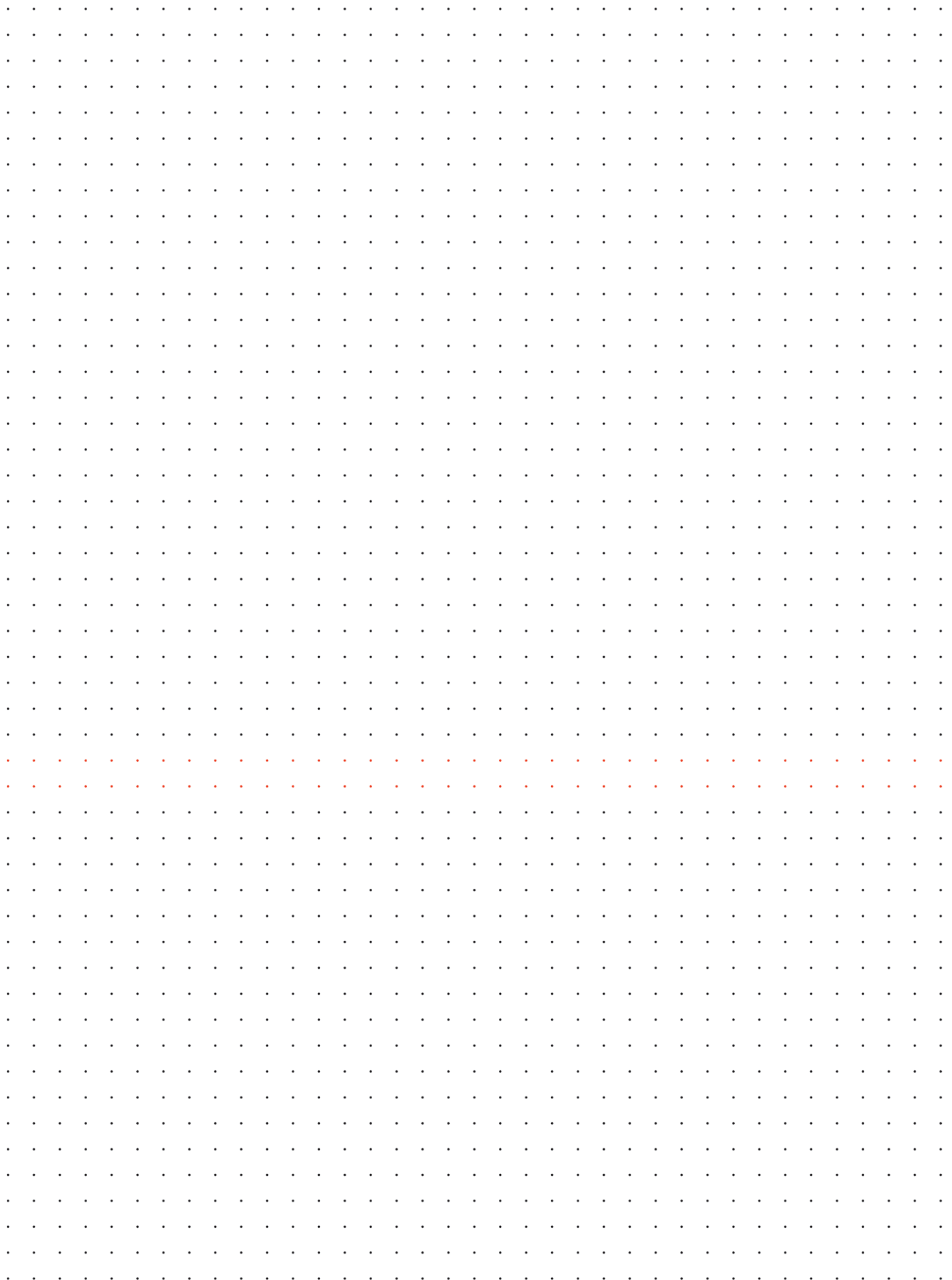

INFINII